

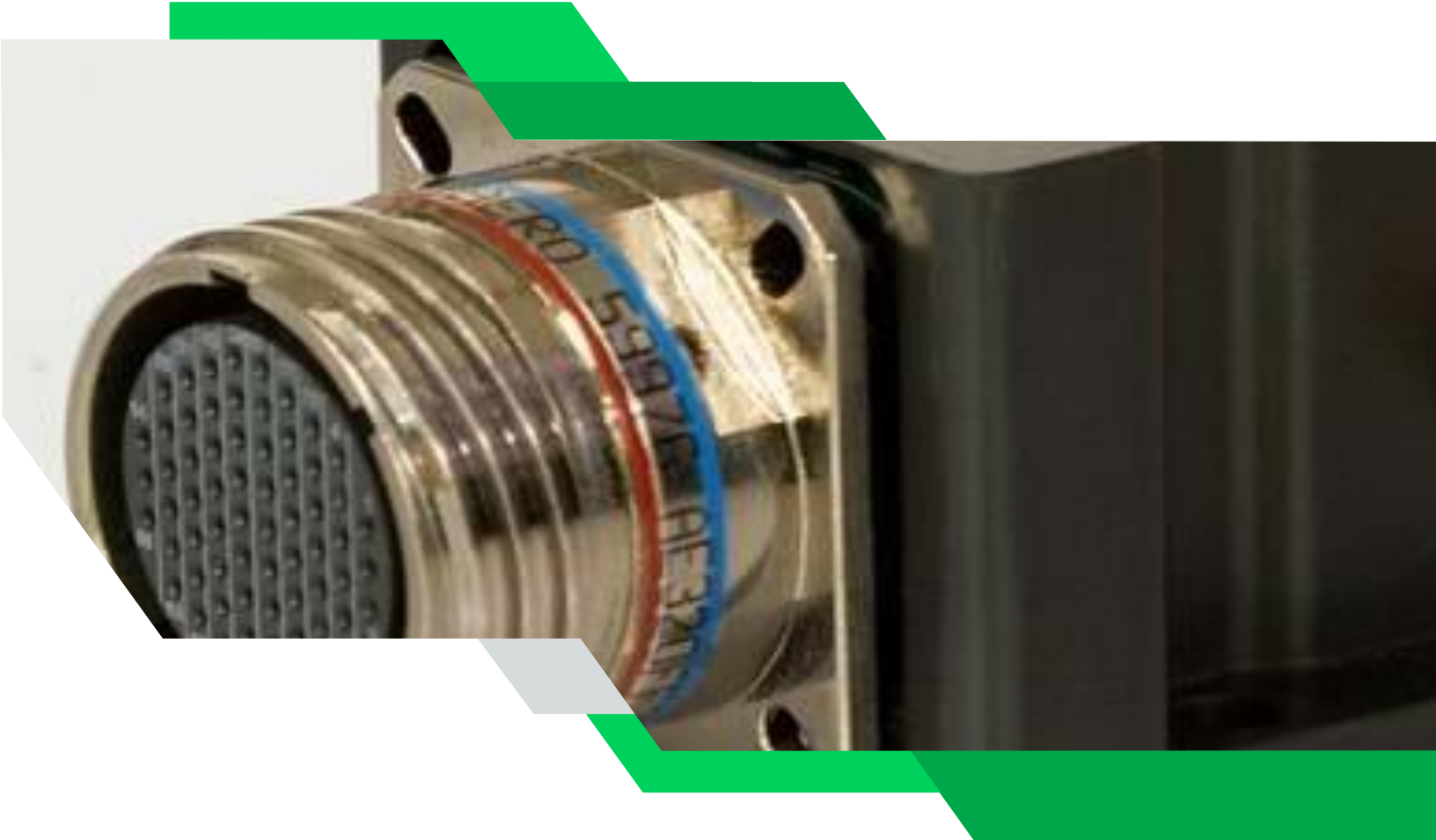

Korry

Illuminating. Always.



Integrated Avionics Computer

Industry-leading signal-conversion and data-concentration

Korry's NextGen Integrated Avionics Computer (KIAC) is an evolutionary step in our already successful Data Concentration Unit (DCU) product line. The new IAC benefits from Korry's mature and extensive experience in the field of airborne computing, allowing Korry to meet ever evolving and complex data processing needs.

Korry's pedigree in signal and data conversion is derived from designing, manufacturing and fielding operational DCUs. Korry's avionics computers are highly modular and incrementally certifiable, offering a wide array of

interface options including field loadable software capabilities. The KIAC scalable form factor and modular architecture is revolutionary and utilizes common VITA-74 small form factor modules as building blocks to meet the customer's airborne computing needs.

The final form factor of the KIAC is driven by customer requirements detailing the number of I/O pinouts, computing, graphics requirements and associated connectors.



Versatile multi-platform NextGen open architecture with configurable I/O channels and multiple circuit interface options

Korry's highly configurable NextGen Integrated Avionics Computers can accommodate any installation or application requirements. They are ideal for simple "store and forward" data concentration applications, as well as perfect for handling highly complex, high-volume, low-latency system solutions with high performance, connectivity and computing capabilities.

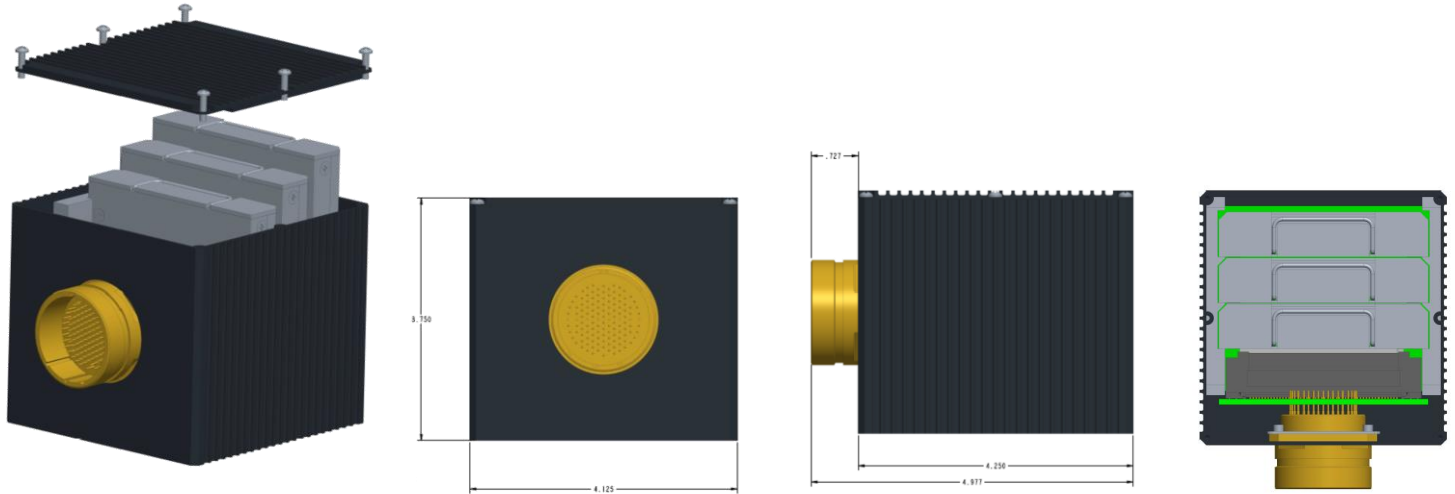

Circuit Interface Options

- Analog
- ARINC-429
- ARINC-664P7
- ARINC-717
- ARINC-818
- ARINC-825 (CAN bus)
- Chip detector
- Discrete input
- Discrete input or output
- Discrete output
- DVI
- Ethernet
- Frequency / Pulse
- IEEE-1394B
- Lamp driver
- MIL-STD-1553
- Multi-wire discrete
- Resistive
- RS-170
- RS-422
- RS-485
- Solid state relay
- Synchro
- Thermocouple

Standards

- AC 20-170
- ARINC-615A (Data load)
- ARINC-653 (RTOS)
- ARINC-661 (CDS)
- ARINC-664P7 (CDN)
- ARP-4754A
- ARP-4761
- DO-297
- ETSO-2C153
- ETSO-C214
- MIL-STD-461E
- MIL-STD-704F
- MIL-STD-810G
- RTCA-DO-160G
- RTCA-DO-178B/C Level A
- RTCA-DO-254 Level A
- VITA-74

Features

- Proven interface circuits
- Passive cooling
- VITA-74 modular design
- Full BITE / health management
- Host 3rd party software modules (DAL A to DAL E)
- Fully environmentally tested
- ETSO-2C153 certified modules
- Robustly partitioned open architecture computing platform
- DAL A highly configurable & scalable computing platform
- ARINC-661 CDS graphics compliant
- Supports incremental certification (AC 20-170)

Standard Certified Modules

- Common Processing Module (CPM)
 - ARINC-653 RTOS Computing Platform
- Graphics Processing Module (GPM)
 - ARINC-661 CDS Graphics Server
- Input / Output Module (IOM)
- Common Data Network (CDN)
- Power Supply Module (PSM)
 - 28VDC or 115VAC@400Hz Power Supply
- Power Supply Hold Up Module
- Mass Storage Module (MSM)
 - SATA Drive Mass Memory Storage



FAA CERTIFIED



Korry

Illuminating. Always.

For more information contact us at:
+1 425-297-9700 or sales@korry.com

www.korry.com

Korry Electronics
11910 Beverly Park Rd.
Everett, WA 98204